

Endless »» Opportunities

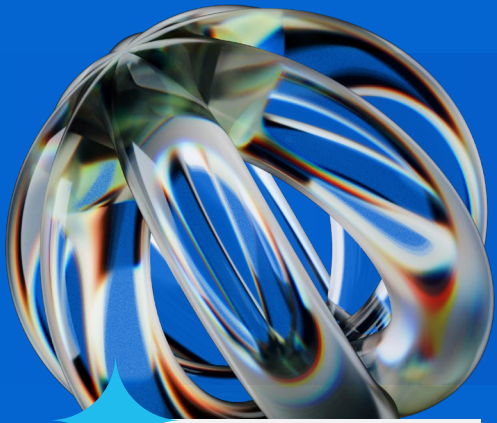



Contents

01

COMPANY
OVERVIEW

03 - 16

02

PRODUCT OFFERINGS

17 - 36

03

BRAND PROMOTION

37 - 52

04

SUSTAINABILITY
INITIATIVES

48 - 53

05

WAY
FORWARD

54 - 60

06

FINANCIAL
PERFORMANCE

61 - 69

01

Company Overview

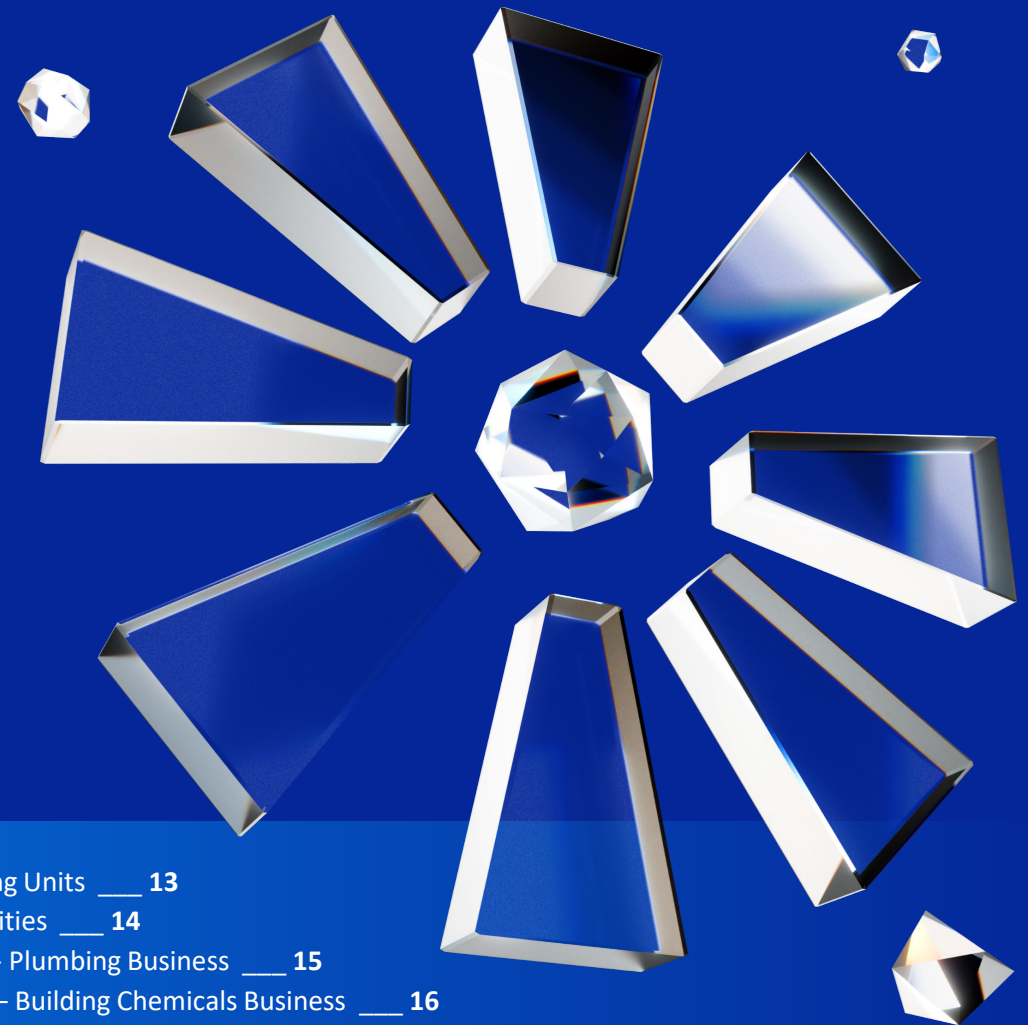

Astral at a Glance ___ **04**

Presence in Nine High-Growth Business Categories ___ **06**

Astral Journey ___ **07**

Awards & Certifications Achieved in FY26 ___ **08**

Pipes, Bathware & Water Tanks Mfg. Units ___ **09**

Adhesives & Construction Chemicals Mfg. Units ___ **12**

Paints Manufacturing Units ___ **13**

Manufacturing Facilities ___ **14**

Pan India Presence - Plumbing Business ___ **15**

Pan India Presence – Building Chemicals Business ___ **16**

Astral at a Glance (1/2)

1996

ASTRAL INCORPORATED

40+

EXPORT TO COUNTRIES

9,500+

EMPLOYEES

54

DEPOTS

21

MANUFACTURING UNITS

5,97,089

PRODUCTION CAPACITY (M.T. PA)

18

Plumbing and water Tanks

15

Adhesives

02

Faucets

19

Paints

12

Plumbing and water Tanks

05

Adhesives

01

Faucets

03

Paints

4,21,445

Pipes, Water Tanks & Bathware

1,02,958

Adhesives & Sealants (India)

36,686

Adhesives & Sealants (UK & US)

36,000

Paints

03 Countries

MANUFACTURING PRESENCE

3,990+

DISTRIBUTORS

2,70,000+

DEALERS

Astral at a Glance (2/2)

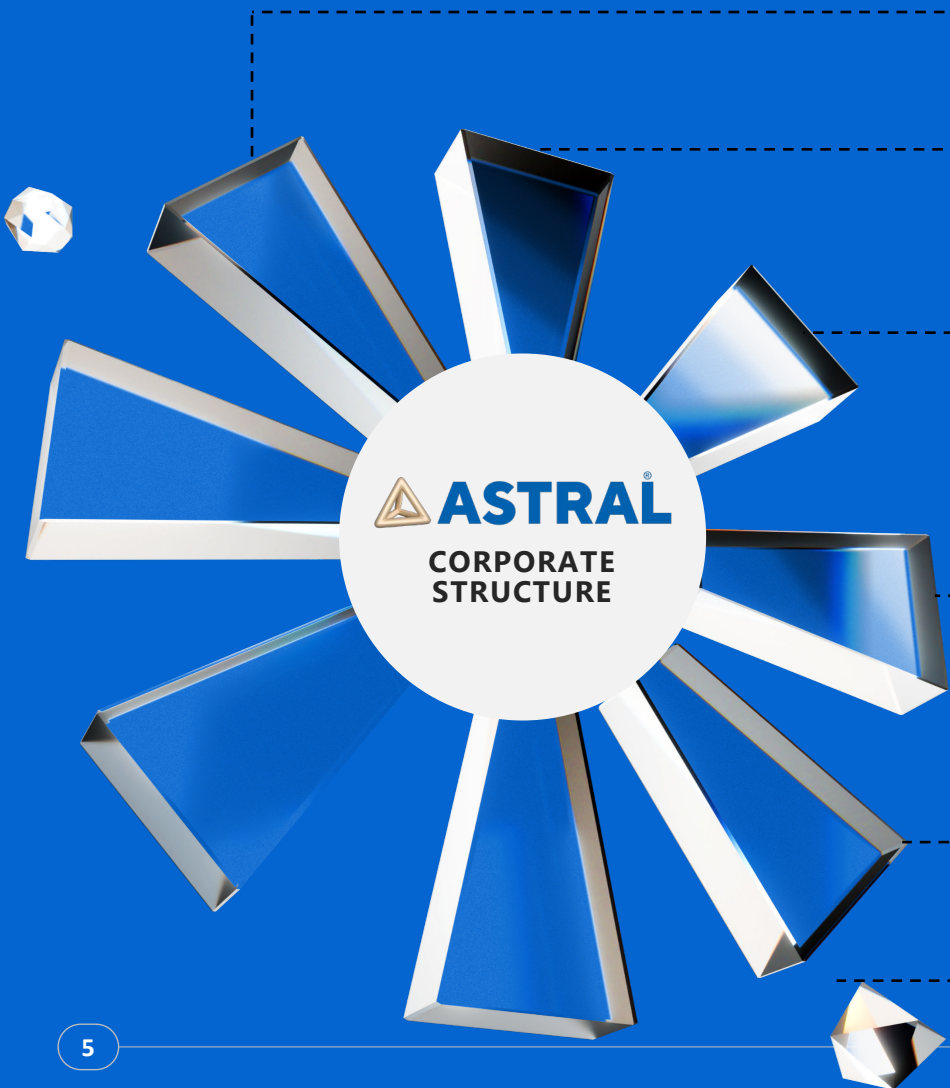

80%

NEXELON CHEM PVT. LTD.

100%

ASTRAL CHEMIE LTD.
(FORMALLY KNOWN AS ASTRAL COATINGS PVT. LTD.)

100%

SEAL IT (UK)

100%

SISL (BOND IT) IRELAND

100%

SEAL IT (USA)

100%

ASTRAL FOUNDATION

50%

APL (KENYA)

100%

AL-AZIZPLASTICS PRIVATE LIMITED

Presence in Nine High-Growth Business Categories

PIPES



WATER TANKS



BATHWARE



SPECIALIZED VALVES



INFRASTRUCTURE SOLUTIONS



SPECIALIZED FITTINGS



ADHESIVES AND SEALANTS



PAINTS



CONSTRUCTION CHEMICALS

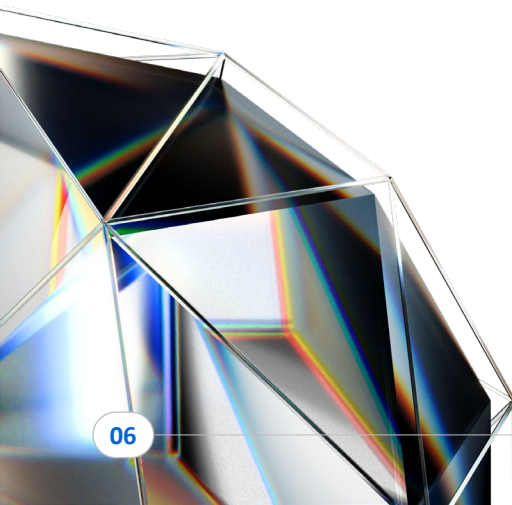

Astral Journey



**ASTRAL
INCORPORATED**

1996

2014-16

2018-20

2021

2022

2023

2024

2025-26

Acquired Seal It Limited, UK

Acquired Resinova Chemie Limited

Salman Khan endorsed the brand

Enters the Billion \$ Market cap club

Fortune India 500 Company

Launch of CPVC Pro

USA Plant of Seal It Limited Operational

Ghiloth Plant Commissioned

Acquired Rex Polyextrusion Limited

Acquired Water Tank Business and launched Sarita by Astral

Ranveer Singh comes on board as Brand Ambassador

Introduced India's first Anti Viral Water Tanks – Cleo & Vito

Expanded product portfolio by introducing HDPE Pro, Under Ground Pipes & Eco Pro

BondTite Pro Launch

Drain Pro Launch

Bhubaneswar Plant operational

Astral Enters Bathware Category

Astral Enters Paints segment by acquiring controlling stake in Gem Paints

Appointed Allu Arjun as brand ambassador to strengthen brand recall in Southern Indian markets

Celebrated 25 years of Astral

Dahej - Adhesive Plant operational

Launched RainWay

Launched Industrial Ball Valve & Plumbing Union Ball Valve

Achieved Great Place to Work Certification for 2023

Launch of Astral Paints

Collaboration with Jawan and Dunki

A Great Place to Work Certification 2024

PTMT launch

Astral Fire Pro got UL listing as well ISI approval for both Pipes and Fittings

Ranbir Kapoor came onboard for Bondtite

Astral Pipes Kanpur plant becomes operational

Astral Adhesives entered into modern trade

New bathware products launched - Thermostatic diverter and body jets

ChemFlow, Industrial pipe launch

Awards & Certifications Achieved in FY26



—
Superbrands
(Astral Pipes &
Bondtite)



—
India's
Most Trusted
Pipe Brand

Pipes, Bathware & Water Tanks Mfg. Units – Installed Capacity (1/2)

P W



SANTEJ

80,376 M.T. PA

P



DHOLKA

77,594 M.T. PA

P W



GHILOTH

59,942 M.T. PA

P W



HOSUR

53,856 M.T. PA

B



JAMNAGAR

1,055 M.T. PA

P



SANGLI

40,244 M.T. PA

KEYS:

- P** Pipes
- W** Water Tanks
- B** Bathware
- S** Specialized Fittings

Pipes, Bathware & Water Tanks Mfg. Units – Installed Capacity (2/2)

P W



AURANGABAD

11,686 M.T. PA

P



SITARGANJ

5,076 M.T. PA

P W



CUTTACK

31,862 M.T. PA

KEYS:

- P** Pipes
- W** Water Tanks
- B** Bathware
- S** Specialized Fittings

P W



GUWAHATI

10,788 M.T. PA

P W



HYDERABAD

26,124 M.T. PA

P W



KANPUR

19,037 M.T. PA

S



ACHHAD

3,800 M.T. PA

Upcoming Pipes & Water Tanks Manufacturing Unit

KEYS:

- P** PIPES
- W** Water Tanks

KHAMBHAT
LUGESIMTAPA

Adhesives & Construction Chemicals Mfg. Units – Installed Capacity

UK + US

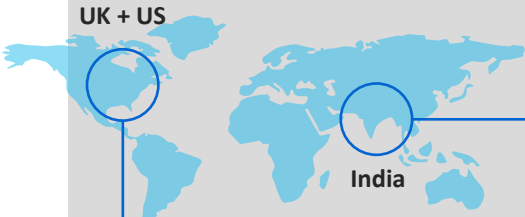

India

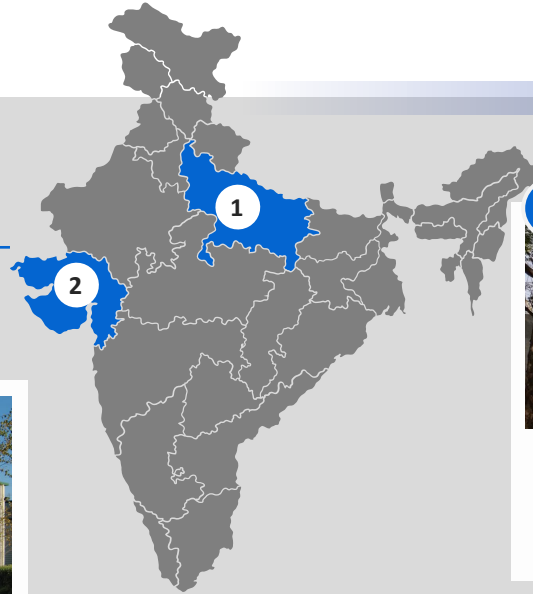

SEAL IT, UK

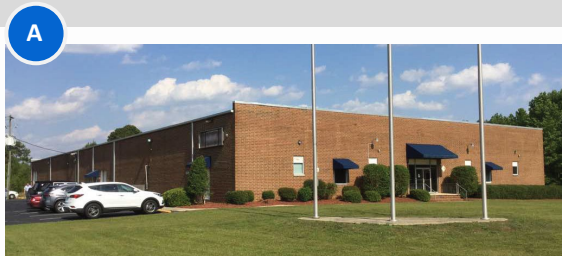

SEAL IT, USA

36,686 M.T. PA
UK + US capacity

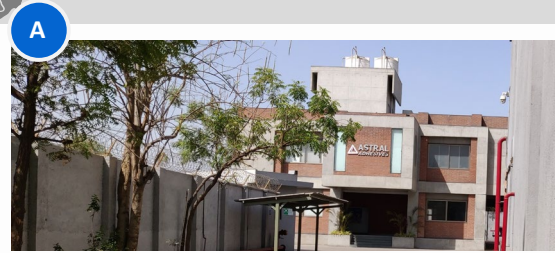

SANTEJ
30,527 M.T. PA



RANIA
33,431 M.T. PA



DAHEJ
39,000 M.T. PA

Paints Manufacturing Units

Installed Capacity

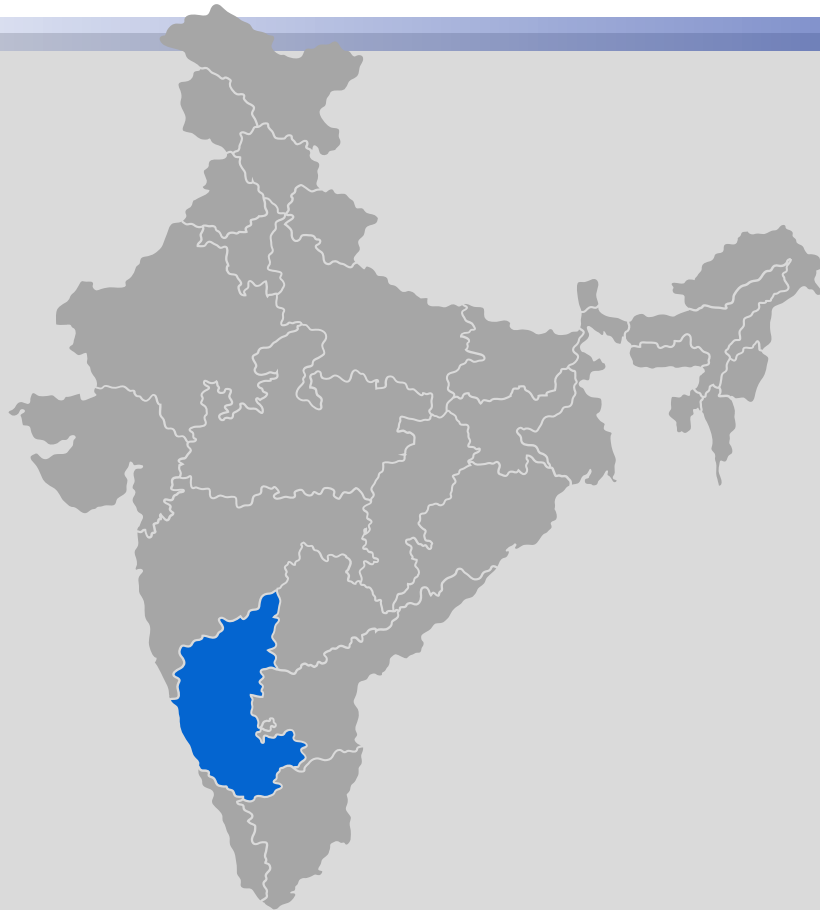

SOMPURA
16,716 M.T. PA



PEENYA
12,447 M.T. PA

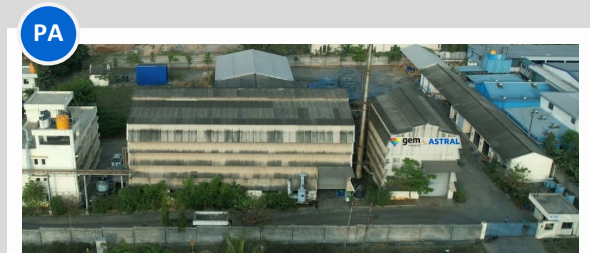

DABASPUR
6,837 M.T. PA

Manufacturing Facilities

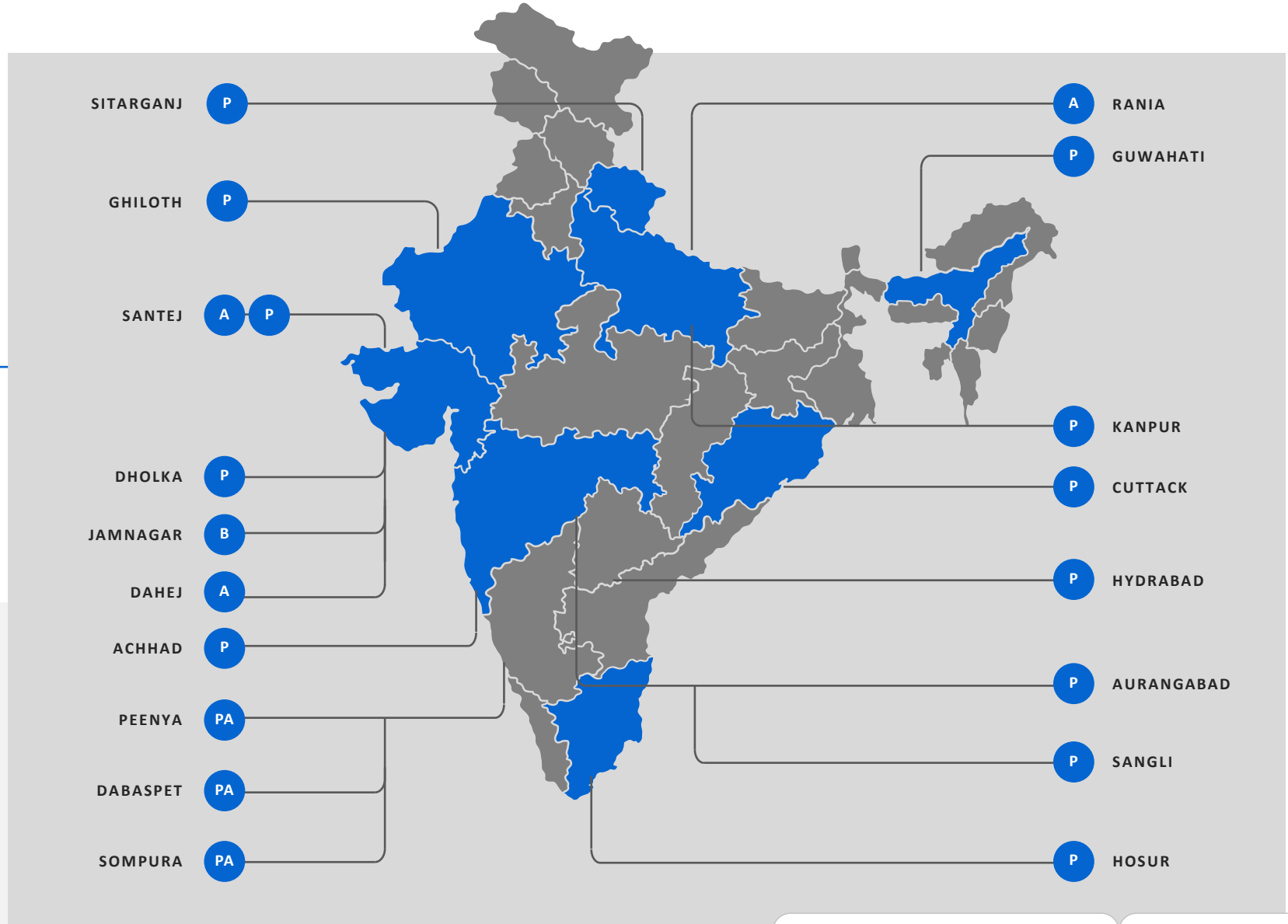
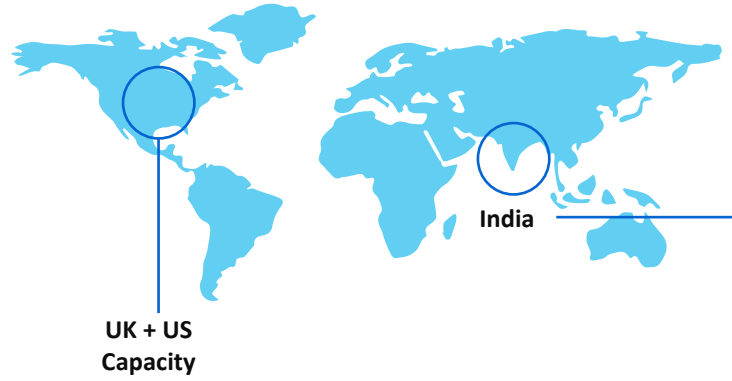

P Pipes

A Adhesives & Sealants

B Bathware

PA Paints

Pan India Presence - Plumbing Business

(Pipes, Bathware & Water Tanks)

TOTAL FIGURES	
Plants	13
Depots	20
Offices	13

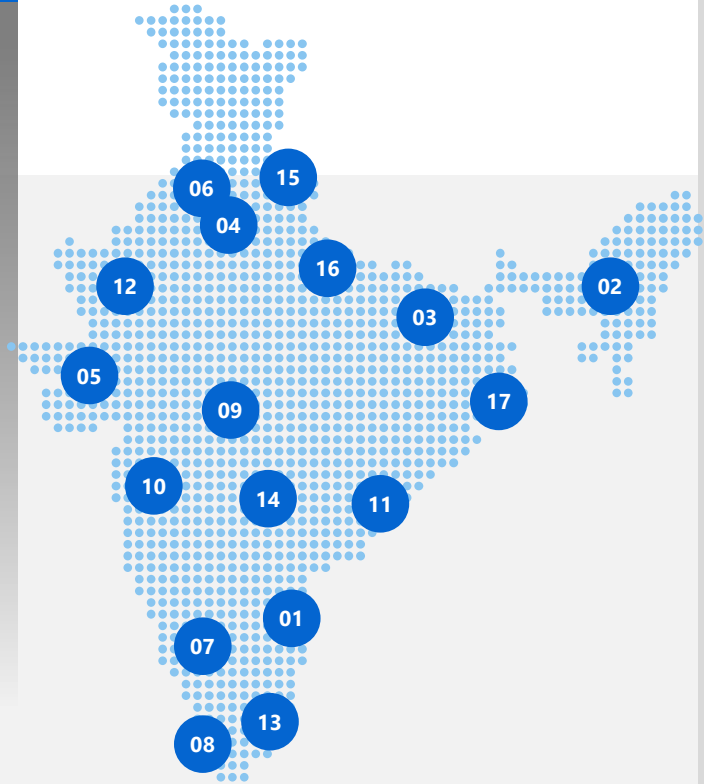

01. ANDHRA PRADESH Depot - 01	02. ASSAM Plant - 01 Depot - 01	03. BIHAR Depot - 01	04. DELHI Depot - 02 Office - 01
05. GUJARAT Plant - 03 Depot - 01 Office - 01	06. HARYANA Depot - 01 Office - 01	07. KARNATAKA Office - 01	08. KERALA Office - 01
09. MADHYA PRADESH Depot - 01 Office - 01	10. MAHARASHTRA Plant - 03 Depot - 03 Office - 02	11. ODISHA Plant - 01 Depot - 01	12. RAJASTHAN Plant - 01 Depot - 02 Office - 01
13. TAMIL NADU Plant - 01 Depot - 02 Office - 01	14. TELANGANA Plant - 01 Depot - 01 Office - 01	15. UTTARAKHAND Plant - 01	16. UTTAR PRADESH Plant - 01 Depot - 02 Office - 01
17. WEST BENGAL Depot - 01 Office - 01			

Pan India Presence – Building Chemicals Business

Adhesives & Sealants, Construction Chemicals, and Paints & Coatings

TOTAL FIGURES

Plants **06**

Depots **34**

Offices **04**

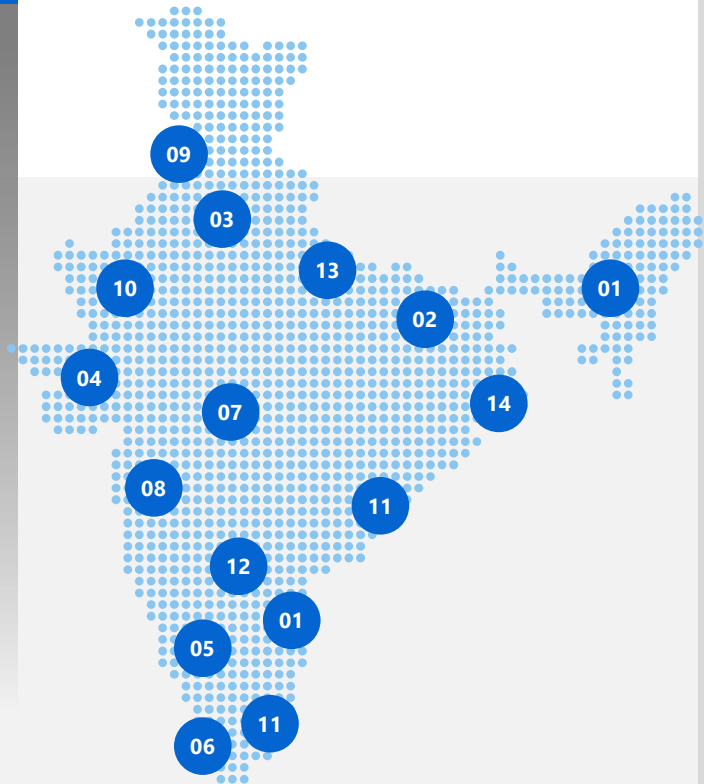

01. ASSAM

Depot - 01

02. BIHAR

Depot - 01

03. DELHI

Depot - 01

04. GUJARAT

Plant - 02
Depot - 04
Office - 01

05. KARNATAKA

Plant - 03
Depot - 06
Office - 01

06. KERALA

Depot - 01

07. MADHYA PRADESH

Depot - 01

08. MAHARASHTRA

Depot - 05
Office - 01

09. PUNJAB

Depot - 01

10. RAJASTHAN

Depot - 05

11. TAMIL NADU

Depot - 05

12. TELANGANA

Depot - 01

13. UTTAR PRADESH

Plant - 01
Depot - 01
Office - 01

14. WEST BENGAL

Depot - 01

02

Product Offerings



Pipes Products Range ___ **18**

Water Tanks ___ **19**

PTMT Bath Series ___ **20**

Plumbing Newly Introduced Products ___ **21**

Bathware Products Range ___ **23**

Adhesives Products Range ___ **26**

Entering Into The Modern Trade &
DIY Solutions ___ **28**

Bond It UK & USA ___ **30**

Trubuild ___ **32**

Astral Paints ___ **33**

Astral Paints - Colour Trip ___ **35**

Gem Paints ___ **36**

Pipes Products Range (1/2)

PLUMBING
SYSTEM



DRAINAGE
SYSTEM



AGRICULTURE
SYSTEM



CABLE PROTECTION
SYSTEM

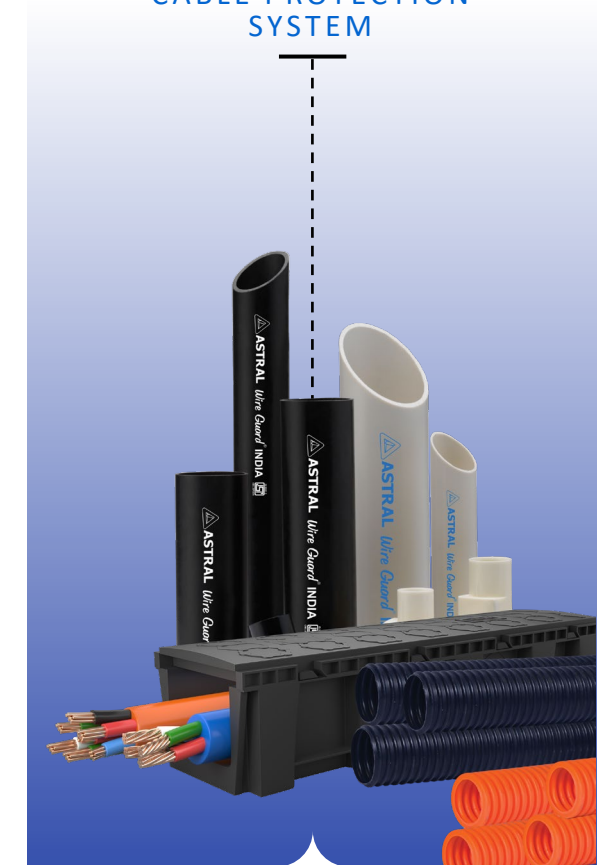

Pipes Products Range (1/2)

INDUSTRIAL PIPING



FIRE PROTECTION



URBAN INFRASTRUCTURE



THERMOPLASTIC BALL VALVES



SPECIALIZED FITTINGS



Water Tanks



PTMT Bath Series



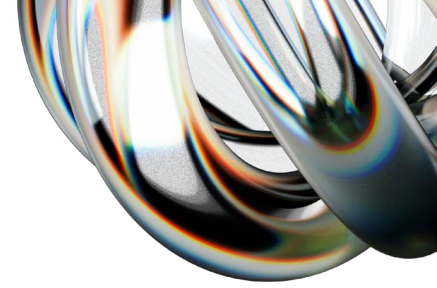

Newly Introduced Products

SWR PRO

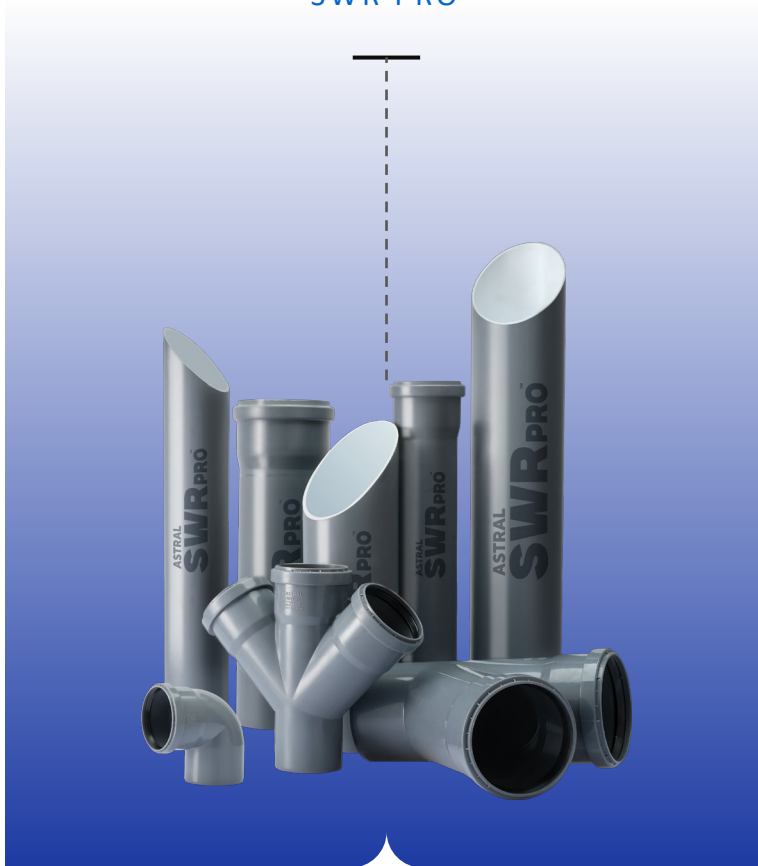

CHEM FLOW

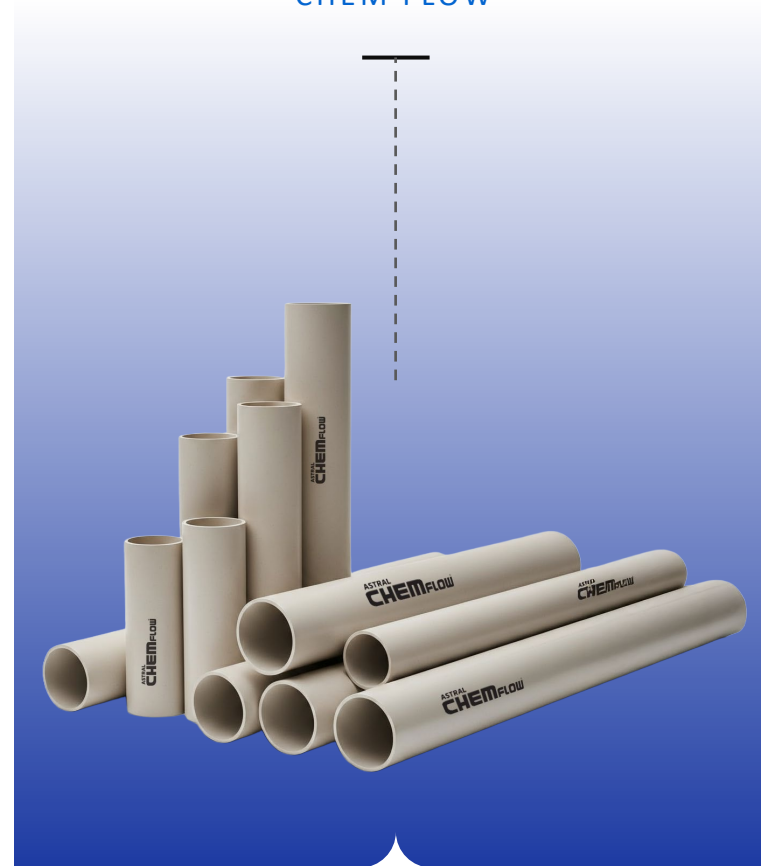

EF DRAIN

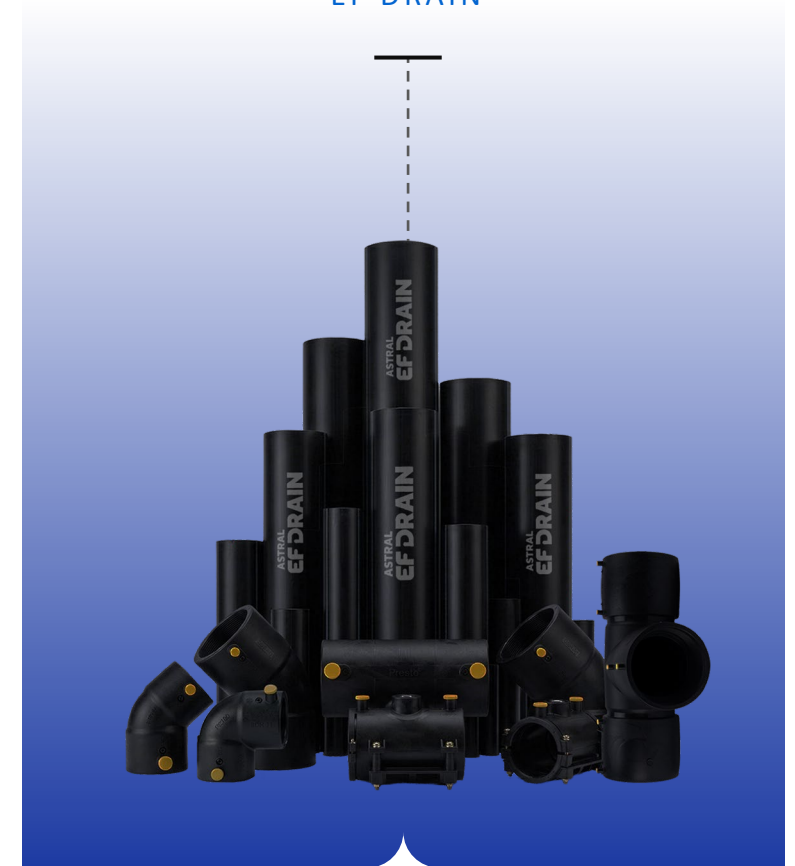

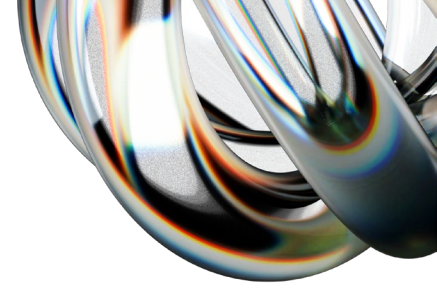

Bathware Products Range (1/2)

GLORIA



PREMIA



Bathware Products Range (2/2)

IMPERIA



CELESTIA



Newly Introduced Products



THERMOSTATIC DIVERTERS



BODY JETS

Round Shape



Square Shape

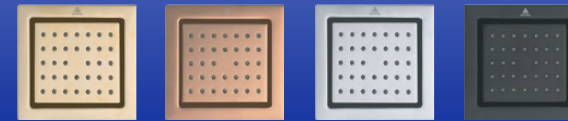

Adhesives Products Range (1/2)

EPOXY ADHESIVES



PVA ADHESIVES



RUBBER ADHESIVES



INSTANT ADHESIVES



Adhesives Products Range (2/2)

INDUSTRIAL RANGE



SILICONE SEALANTS



TAPES



WALL PUTTIES



SOLVENT CEMENTS



Entering Into Modern Trade & DIY Solutions (1/2)

BONDTITE

BOND CRAFT

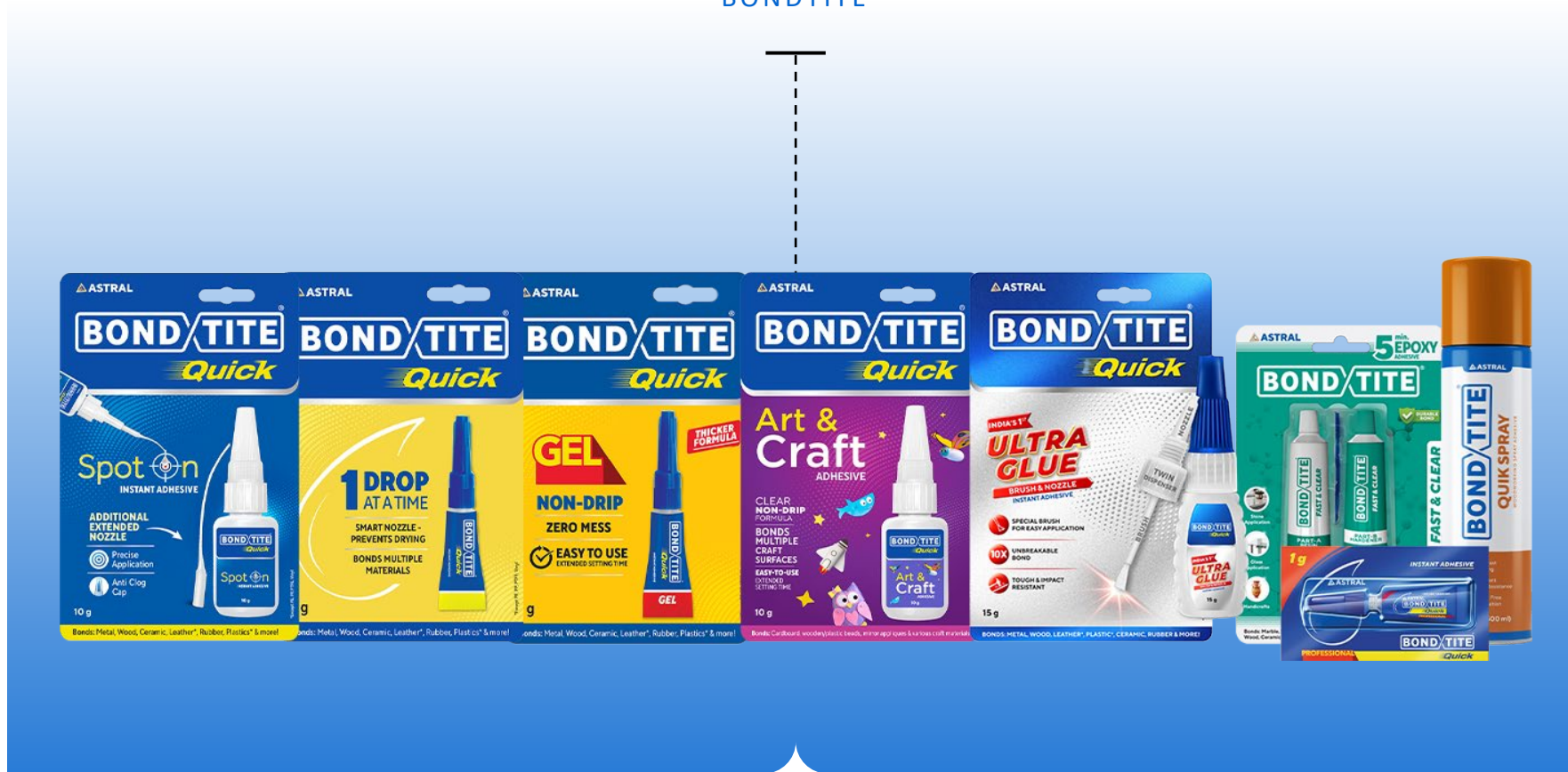

Entering Into The Modern Trade & DIY Solutions (2/2)

RESITAPE



BONDSET



OTHERS



Bond It, UK & USA (1/2)



GBX - NEXT GEN SEALANTS



SILICONE SEALANTS



ROOF SEAL SYSTEM



PU FOAMS AND ADHESIVES



Bond It, UK & USA (2/2)



FLOOR LEVELLING



TILING



WATERPROOFING



Trubuild

WATERPROOFING SOLUTIONS



EXTERIOR COATING SOLUTIONS



TILING & GROUTING SOLUTIONS



Astral Paints (1/2)

INTERIOR EMULSIONS



EXTERIOR EMULSIONS



WATERPROOFING RANGE



SPECIAL EMULSION



Astral Paints (2/2)

PRIMERS



WALL PUTTY



ENAMELS & DISTEMPERS



ANCILLARIES



Astral Paints – Colourtrip

COLOUR
FANDECK



COLOUR TINTING
MACHINE



Gem Paints

INDUSTRIAL COATINGS



INTERIOR EMULSIONS



EXTERIOR EMULSIONS



ENAMELS & DISTEMPERS



Newly Introduced Products

WATERPROOFING



PRIMERS



SPECIAL PAINT



OTHERS



03

Brand Promotion

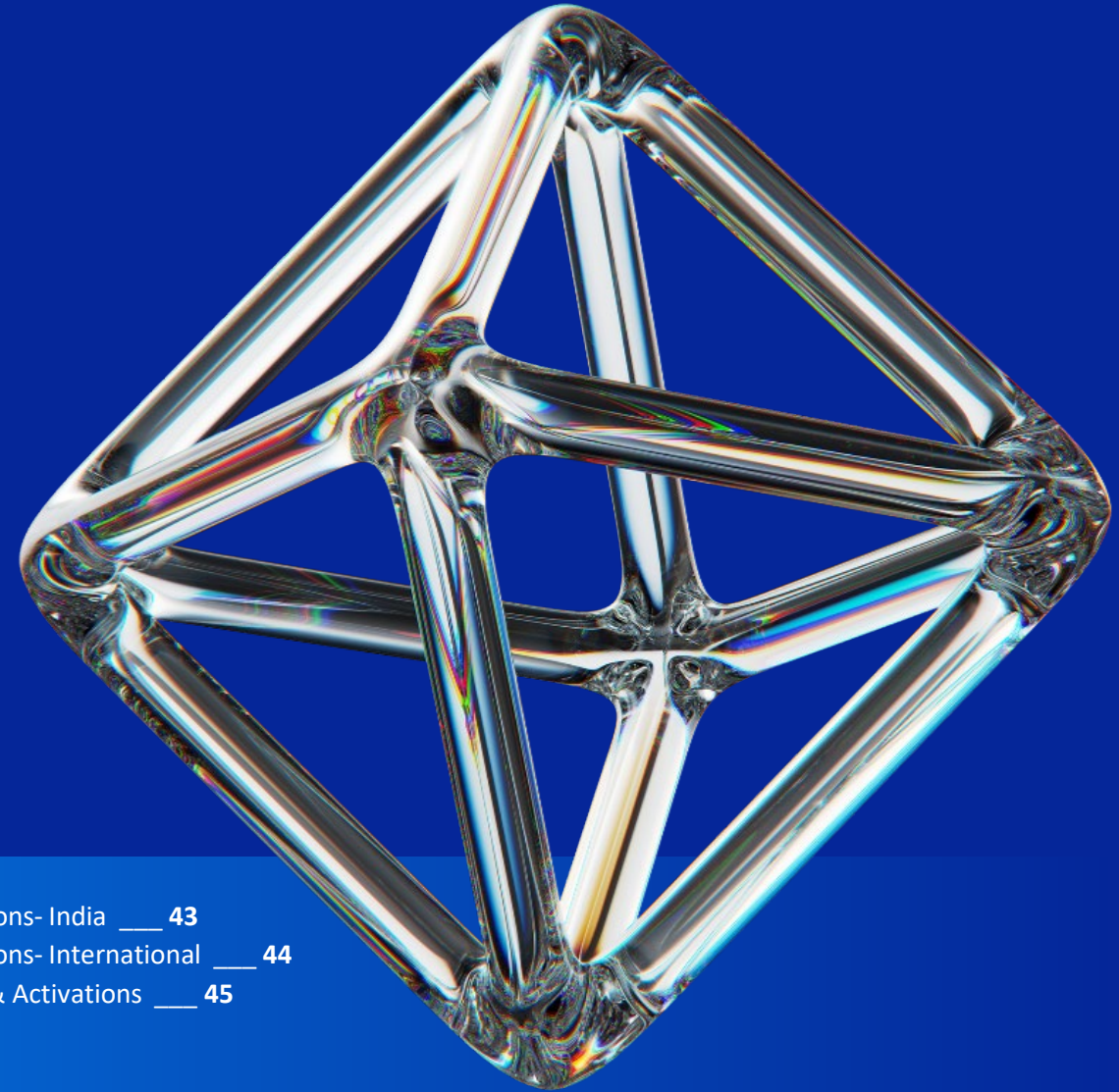

Bondtite gets its First Brand Ambassador

– Ranbir Kapoor ___ 38

Adhesives Branding ___ 39

Centre of Every Moment Campaign ___ 40

Three Teams. One Astral Strong Season. ___ 41

Astral Pipes & Bathware Powers- Dhurandhar The
Revenge ___ 42

Exhibition Participations- India ___ 43

Exhibition Participations- International ___ 44

Innovative Outdoor & Activations ___ 45



Ranbir Kapoor Joins Bondtite as Brand Ambassador



Adhesives Branding- TVC with Ranbir Kapoor



Centre of Every Moment Campaign



Three Teams. One Astral Strong Season.



Astral Pipes & Bathware Powers- Dhurandhar The Revenge

**ASTRAL
PIPES**

**THE
REVENGE**

**PIPES KA
DHURANDHAR**

DHURANDHAR

WRITTEN, DIRECTED & PRODUCED BY ADITYA DHAR
PRODUCED BY JYOTI DESHPANDE
PRODUCED BY LOKESH DHAR

A JIO STUDIOS RELEASE

WELD-ON
SILENCIO
ASTRAL CPVC Pro
ASTRAL Aquarius

Exhibition Participations- India



IPC, Kolkata



PLUMBEX, DELHI



DÉCOR INDIA SHOW, JAIPUR



NAVIG8, BENGALURU



IDAC, MUMBAI



GLAM, SURAT

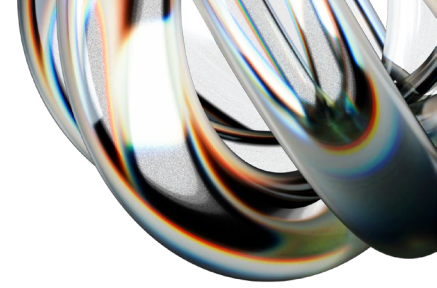

Exhibition Participations- International

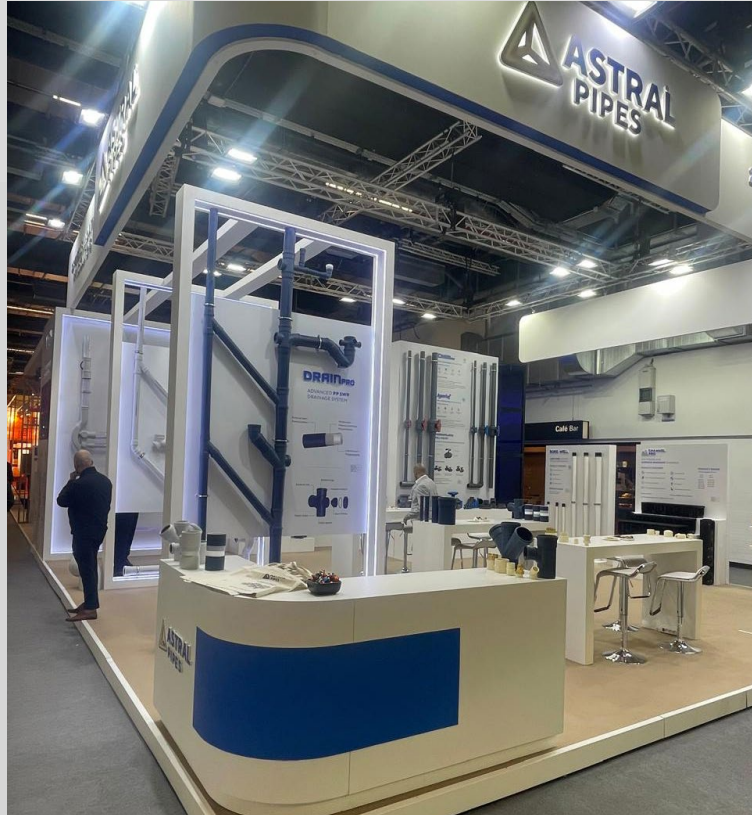

ISH, GERMANY



BIG 5, DUBAI



BIG 5, DUBAI

Innovative Outdoor & Activations (1/3)



Innovative Outdoor & Activations (2/3)



Innovative Outdoor & Activations (3/3)



03

Sustainability Initiatives

Empowering Communities, Enhancing Lives ___ 00

Contributing to a Better Society ___ 00

Sustainability & ESG Highlights ___ 05

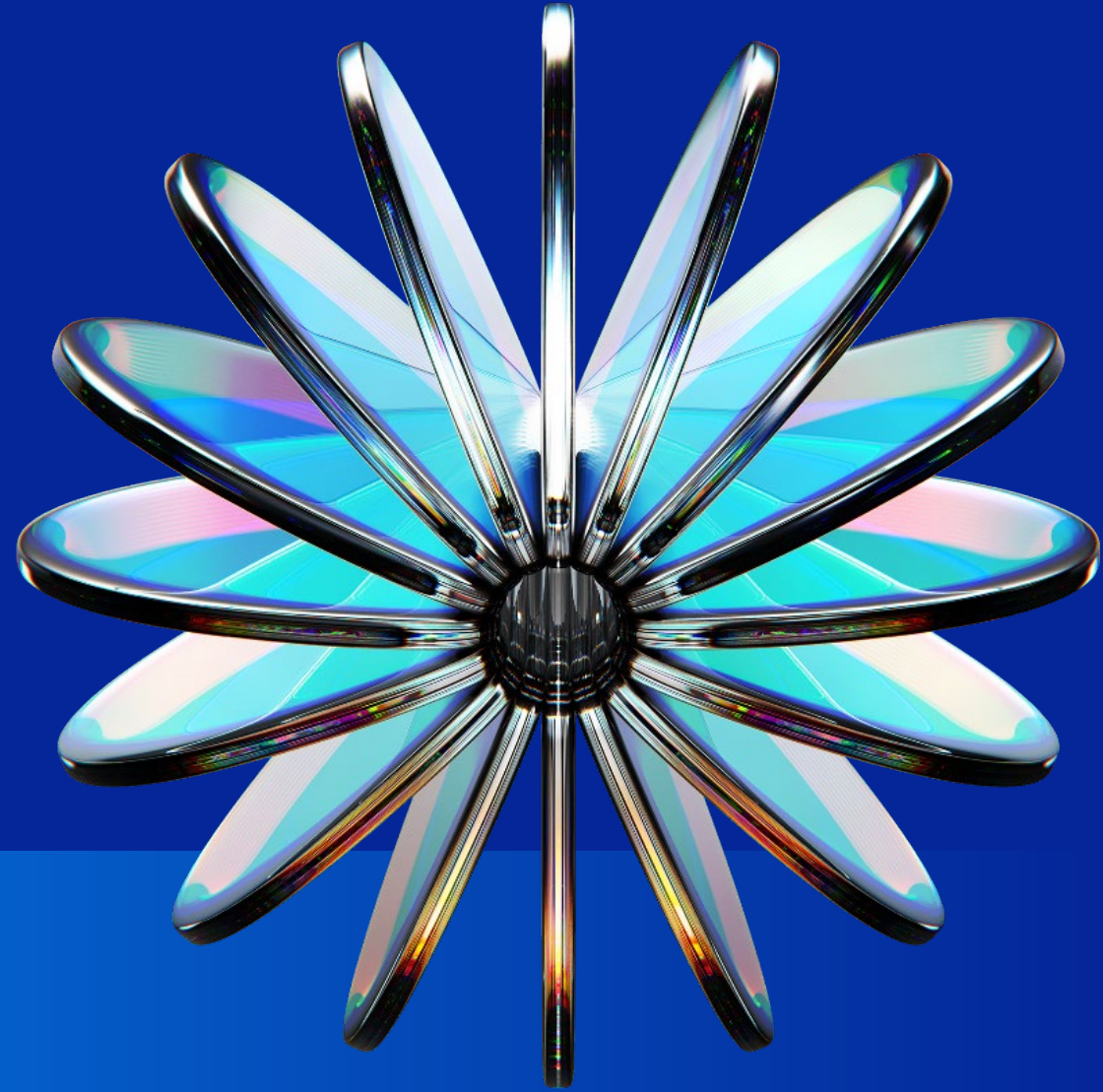

Empowering Communities, Enhancing Lives

While financial success is a key metric of our achievements, we place equal value on the development and empowerment of the communities where we operate.

Bearing this in mind, we have partnered with various institutions to cater specifically to their unique needs.

Education



Environment



Wildlife
Conservation



Support to
Disabled
People



Health



Infrastructure
Development



INITIATIVES

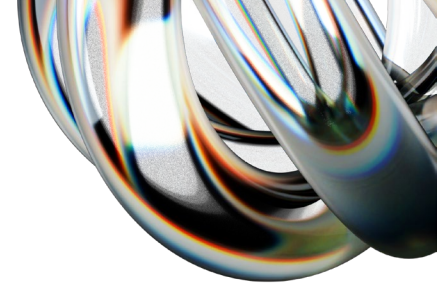

Contributing to a Better Society (1/3)



CONSERVATION ACTIONS FOR THE ENDANGERED CARACAL



LEOPARD ECOLOGICAL PROJECT



SNAKE & MONITOR LIZARD CONSERVATION



GHARIYAL ECOLOGY PROJECT



EMPOWERING TRIBAL CHILDREN IN KANHA



FIRE PREVENTION AWARENESS

Contributing to a Better Society (2/3)



SARATHI PROJECT



SHIKSHA SARATHI PROJECT



AAROGYAM PROJECT



PARYAVARAN PROJECT



SAVE GIRL SAVE TREE PROJECT



BUDGERIGHAR ENCLOSURE PROJECT AT SUNDARVAN

Contributing to a Better Society (3/3)



SANJEEVANI PROJECT



DISHA PROJECT



KAUSHALYA PROJECT



PLASTIC MUKT PARYAVARAN



DUDHWA CAPACITY BUILDING

Sustainability & ESG Highlights

- 01 CSR supported **41,24,225 beneficiaries** through projects in FY 2025–26.
- 02 **39% increase** in electricity generated from renewable energy sources.
- 03 **7 MW clean energy initiative** through solar and wind power generation.
- 04 **Digital ESG transformation** implemented for enhanced data collection and reporting.
- 05 **GRIHA-certified Green Building Products:** Aquasafe | Silencio | Aquarius | Drain Pro | Drainmaster.
- 06 **ISO 9001:2015 QMS** implemented at Cuttack and Hyderabad manufacturing units.

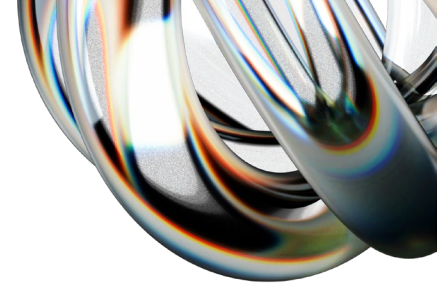

Our ESG Score Trend

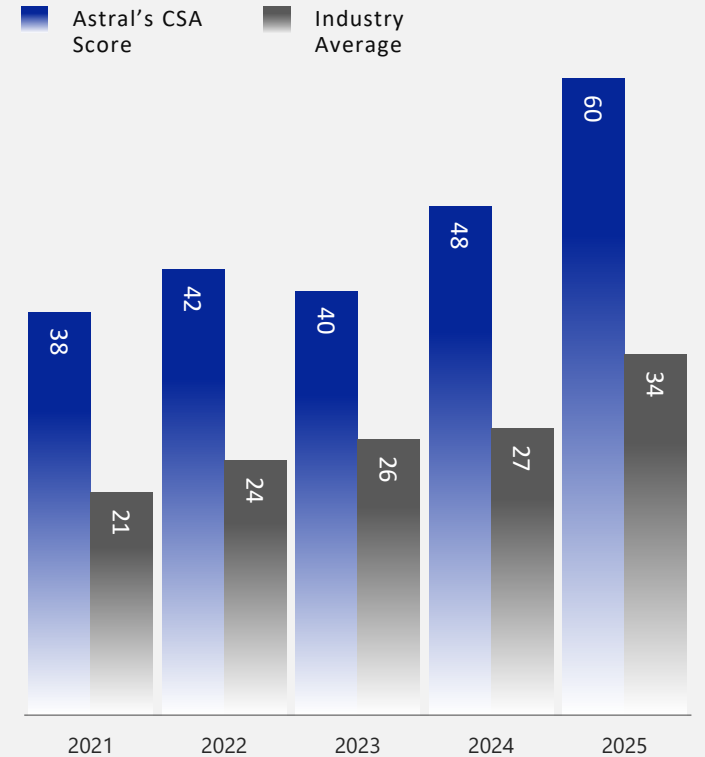

05

Way Forward

Management Commentary ___ 55
Industry Outlook Pipes ___ 56
Revenue Drivers for Next 5 years – Pipes ___ 57
Industry Outlook Adhesives and Paints ___ 58
Revenue Drivers for Next 5 years – Adhesive ___ 59
Option Value ___ 60



Management Commentary

The decision to set up a captive CPVC Resin plant, through the acquisition of a stake in Nexelon Chem, will make Astral the only CPVC pipe manufacturer in India to produce its own resin.

FY26 was a year of significant volatility in polymer prices across the industry. Against this backdrop, Astral delivered on its stated commitments across all three business verticals.

In the Plumbing business, Astral recorded the highest volume growth and the highest EBITDA margins amongst all leading players in the piping industry. The company grew its market share in a difficult year, which reflects the investment made over the years in distribution, capacity, and product quality. In Adhesives, the India business performed in line with guidance. The UK operations have shown improvement, and the trajectory is expected to continue into FY27. In Paints, the company delivered healthy topline growth. Profitability remains below desired levels. The network investment has been made and the focus in FY27 will be on converting that base into EBITDA profitability.

Two developments are worth highlighting. The decision to set up a captive CPVC Resin plant, through the acquisition of a stake in Nexelon Chem, addresses a structural gap in the business. CPVC resin is currently imported by all pipe manufacturers in India. Captive production will reduce input costs, improve margins on CPVC pipes and fittings, and strengthen Astral's competitive position in the CPVC segment, enabling further market share gains. The full benefit is expected to reflect in the numbers from FY28. The appointment of Ranbir Kapoor as Brand Ambassador for Bondtite marks a deliberate shift towards building consumer pull in the adhesives category, which has historically been driven by contractor and dealer recommendation.

Mr. Sandeep Engineer
CHAIRMAN &
MANAGING DIRECTOR

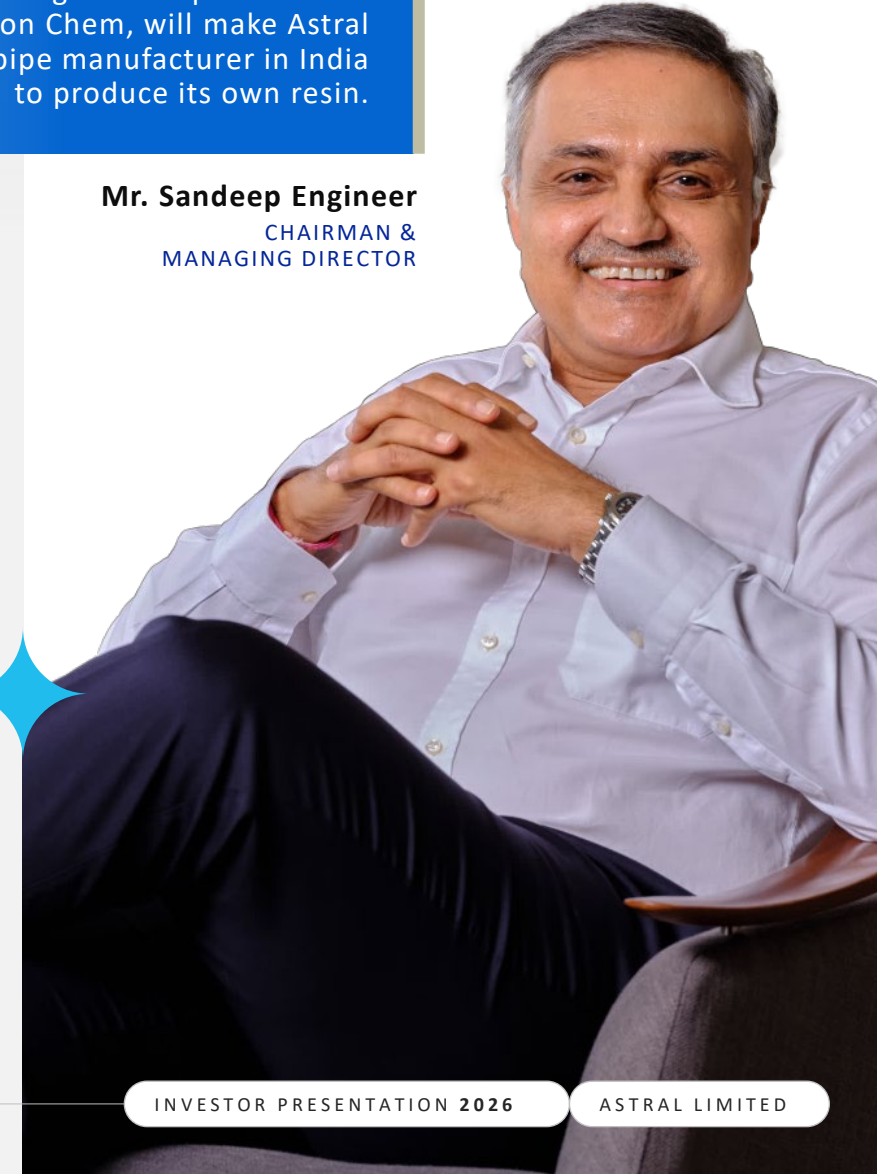

Industry Outlook Pipes



01

The pipes and fittings industry is expected to grow ~8% in volume in FY27. Organised players with strong distribution and certified product portfolios are expected to outperform the industry.

02

Polymer prices, after a year of sharp volatility, are expected to remain elevated. Higher realisations improve fixed cost absorption and support better margins for organised manufacturers.

03

Government infrastructure programmes continue to underpin pipe demand. The Jal Jeevan Mission has been allocated ₹ 67,600 crore in FY27 and extended through December 2028, providing sustained demand visibility for pipes across rural water supply and housing segments.

04

Polymer price volatility has disproportionately impacted smaller, unorganised players who lack the balance sheet strength and procurement scale to absorb input cost fluctuations. This is accelerating the shift of volumes towards organised, branded manufacturers.

Revenue Drivers for Next 5 years – Pipes

01

CPVC RESIN BACKWARD

Astral will be the only CPVC pipe manufacturer in India to produce its own resin. The captive 40,000 MT plant reduces import dependence, currency exposure, and is expected to improve margins on CPVC pipes and fittings from FY28.

02

NEW PRODUCT LAUNCHES

HDPE Pipes, Electro Fusion Fittings, O-PVC, PP-R, PP-H Pipes, and STP-PRO open new markets in gas distribution, industrial piping, and sewage treatment.

03

VALUE-ADDED PRODUCTS

A growing contribution from value-added and newly launched products is improving the overall margin profile of the Plumbing business.

04

DECENTRALISATION

New facilities in Kanpur and Hyderabad have expanded Astral's manufacturing footprint, improving regional reach, service levels, and logistics costs while advancing its decentralised production strategy.

05

SKU DEPTH

Total SKUs have grown from 6,939 to 8,103, enabling a more complete offering across dealer and project channels.

06

BATHWARE

The segment delivered 27.3% sales growth in FY26, with further headroom as product range and distribution expand.

07

FY27 GUIDANCE

Volume growth of ~10 - 15% is targeted for FY27. Value growth is expected to be higher.



Industry Outlook Adhesives and Paints



01

The adhesives and sealants market in India is expected to deliver ~8-10% volume growth in FY27, driven by construction activity, renovation demand, and growing rural consumption.

02

The decorative and industrial paints market is expected to grow ~6-7%, with organised players continuing to expand their share in under-penetrated geographies.

03

Branded players continue to gain share from the unorganised segment, driven by product quality, availability, and application support.

04

Demand for construction chemicals and waterproofing products is growing ahead of the broader adhesives market, supported by the expansion of India's housing base.

05

The UK adhesives market remains under macroeconomic pressure, though early signs of stabilisation are visible.

06

Export opportunities across the Middle East, Africa, and Europe are developing, supported by India's cost competitiveness and improving international presence.

Revenue Drivers for Next 5 years – Adhesive



01

BRAND INVESTMENT

Ranbir Kapoor as Brand Ambassador for Bondtite marks a shift from a trade-driven to a consumer-led model, building long-term pricing power and brand recall.

02

DISTRIBUTION EXPANSION

Present across 13,000 towns with a target of 20,000 towns, providing a longer runway for growth.

03

RURAL PENETRATION

The New Bharat initiative is deepening reach across tier 3 and tier 4 towns in Maintenance, Wood, and Construction Chemicals.

04

TRUBUILD RELAUNCH

Complete waterproofing portfolio relaunched under the Trubuild brand, positioning Astral in a growing and underpenetrated category.

05

BOND IT UK AND US

Post-restructuring, the UK business is expected to move towards improved profitability, with new product launches in the US adding further optionality.

06

FY27 TARGET

~15-20%, against an industry expectation of 8 to 10%.

Option Value

1

PIPING BUSINESS

With new facilities in Kanpur and Hyderabad now operational, the benefits of decentralised manufacturing in market reach, turnaround times, and cost efficiency are expected to become increasingly visible.

2

ADHESIVES

The worst appears to be behind the UK business, with performance expected to improve through FY27. In India, initiatives such as New Bharat are deepening reach into under-served markets.

3

CPVC RESIN

Astral will be the only CPVC pipe manufacturer in India to produce its own resin. The captive 40,000 MT plant reduces import dependence, currency exposure, and is expected to improve volumes and margins on CPVC pipes and fittings from FY28.

4

PAINTS BUSINESS

Network investment is in place. FY27 is expected to deliver EBITDA profitability as revenues scale over the existing cost base. The company is targeting 25% sales growth in FY27.

5

BATHWARE

Growing segment with clear headroom. The company is targeting 25% sales growth in FY27.

6

MEA AND INTERNATIONAL

The Emerging Business portfolio is building international presence in the MEA region across Modern Trade and e-commerce, creating a foundation for long-term growth.

06

Financial Performance

Consolidated Full Year Performance ___ 62
Group Revenue Breakup ___ 65
Plumbing Business ___ 66
Paints and Adhesives Business ___ 69



Consolidated Full Year Performance (1/3)



Note: EPS adjusted for FY21 & FY22 due to issue of bonus shares

Consolidated Full Year Performance (2/3)

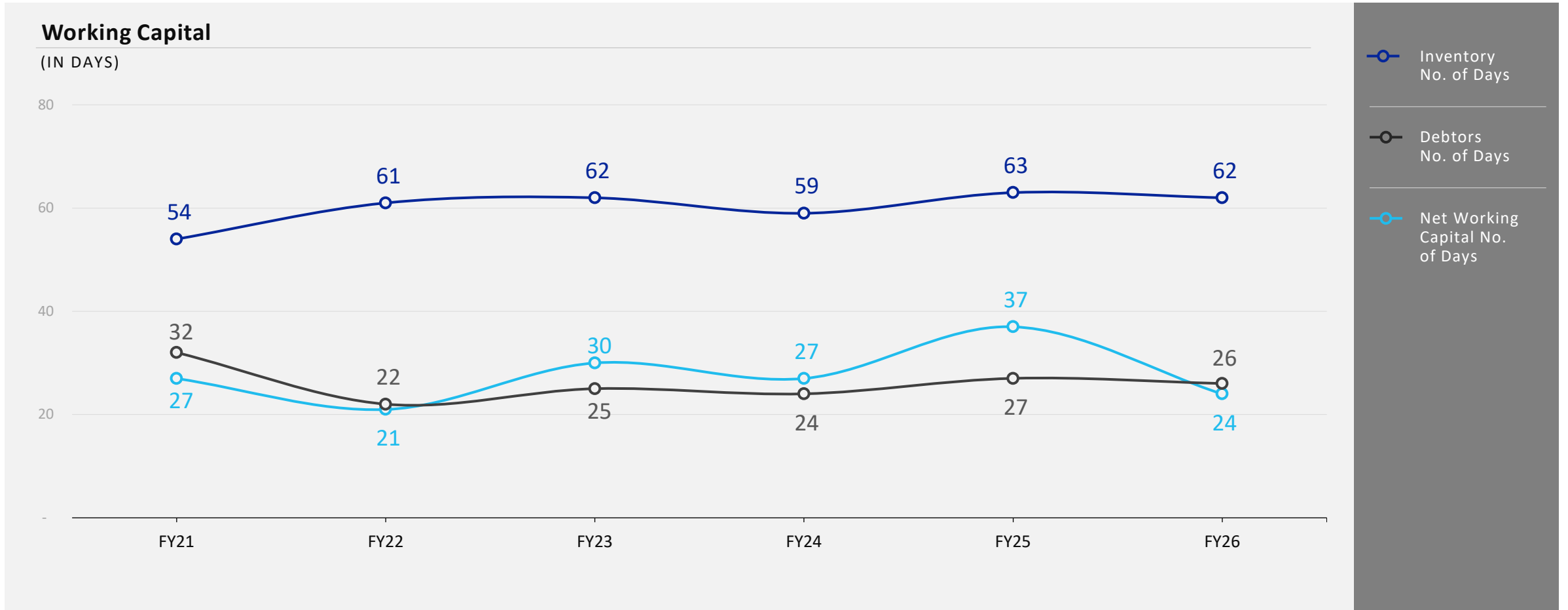

Consolidated Full Year Performance (3/3)

Net Cash Balance

(₹ MN)

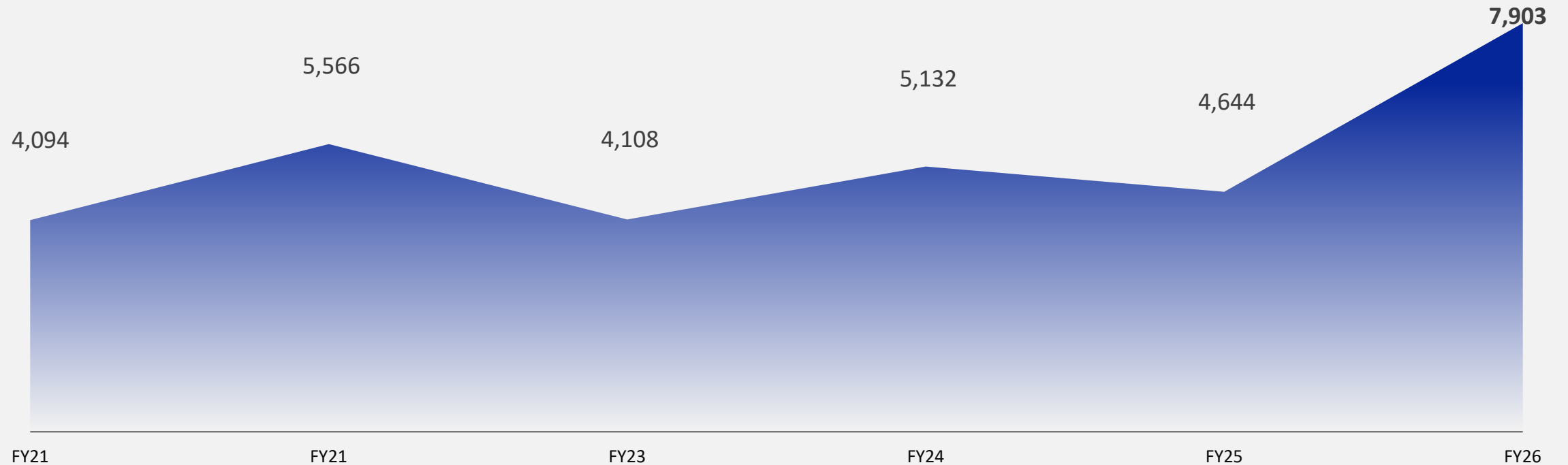

Group Revenue Breakup

FY24

(IN %)

27%

Paints &
Adhesive

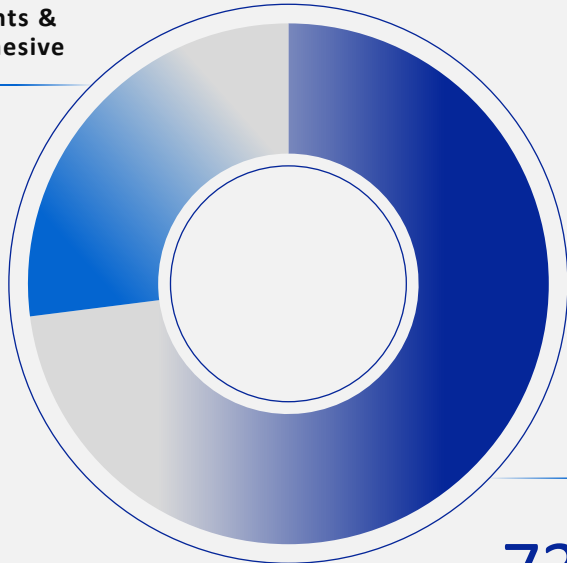

73%

Plumbing

FY25

(IN %)

28%

Paints &
Adhesive

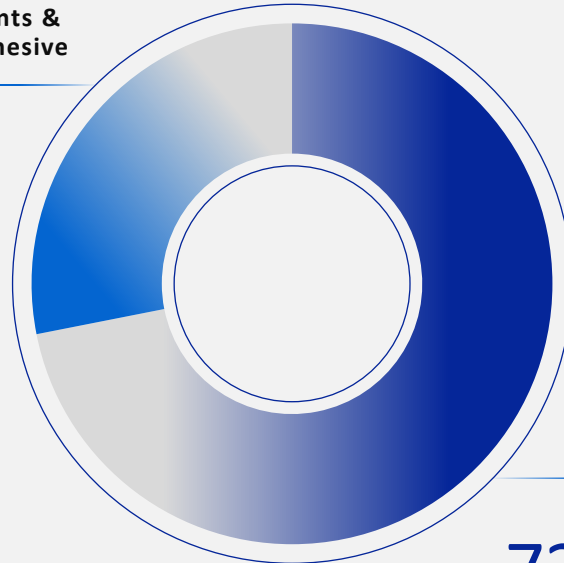

72%

Plumbing

FY26

(IN %)

29%

Paints &
Adhesive

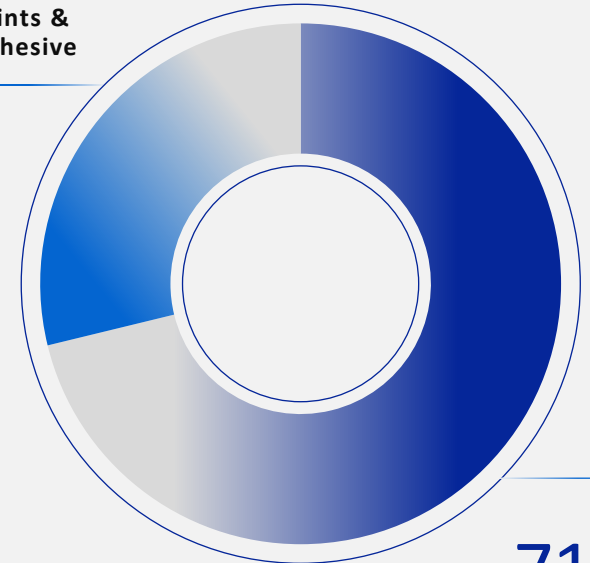

71%

Plumbing

Plumbing Business (1/3)

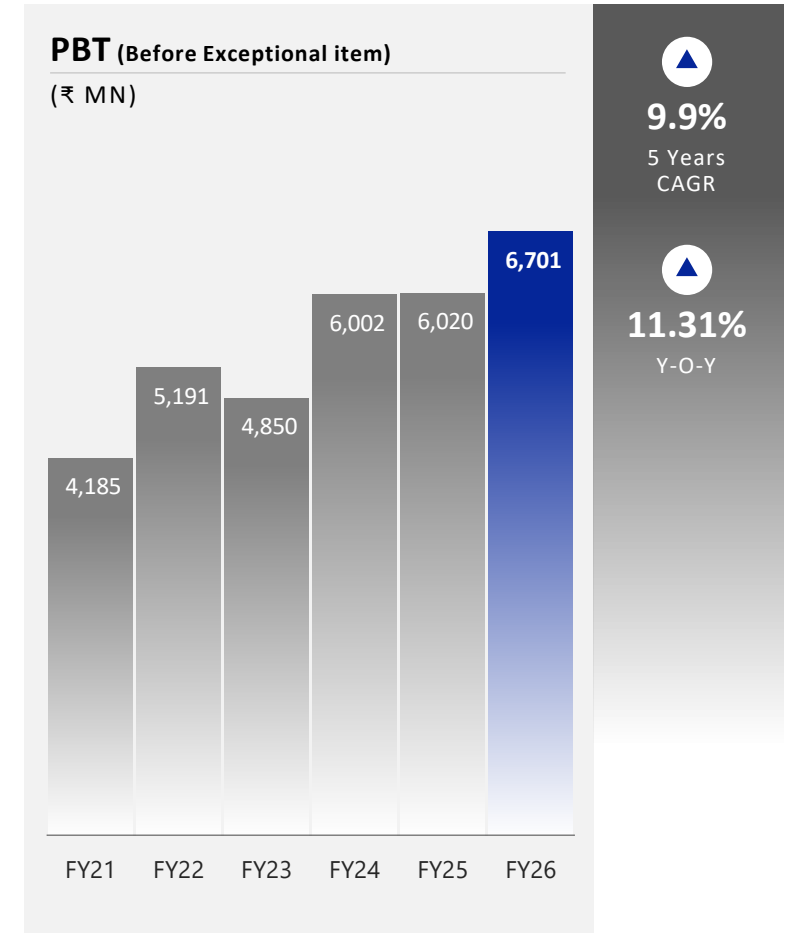
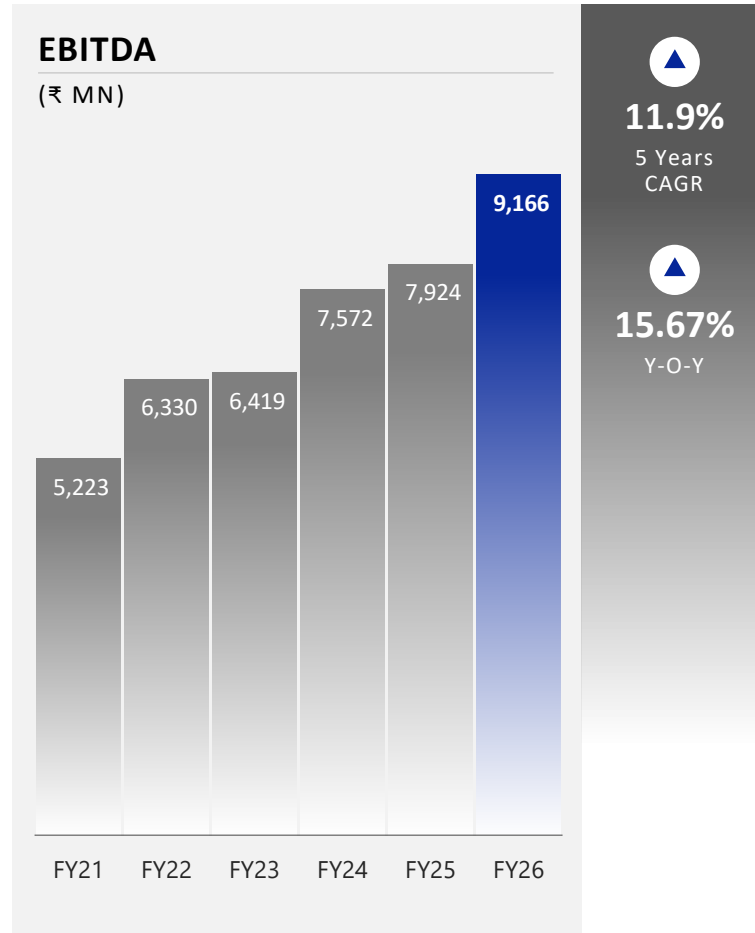
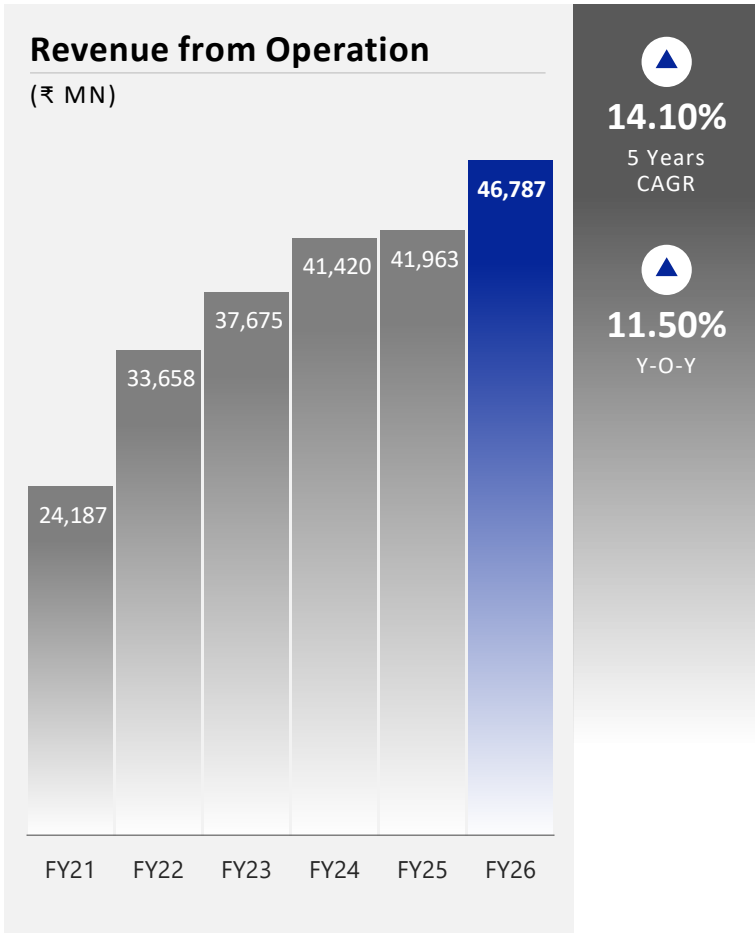

Plumbing Business (2/3)

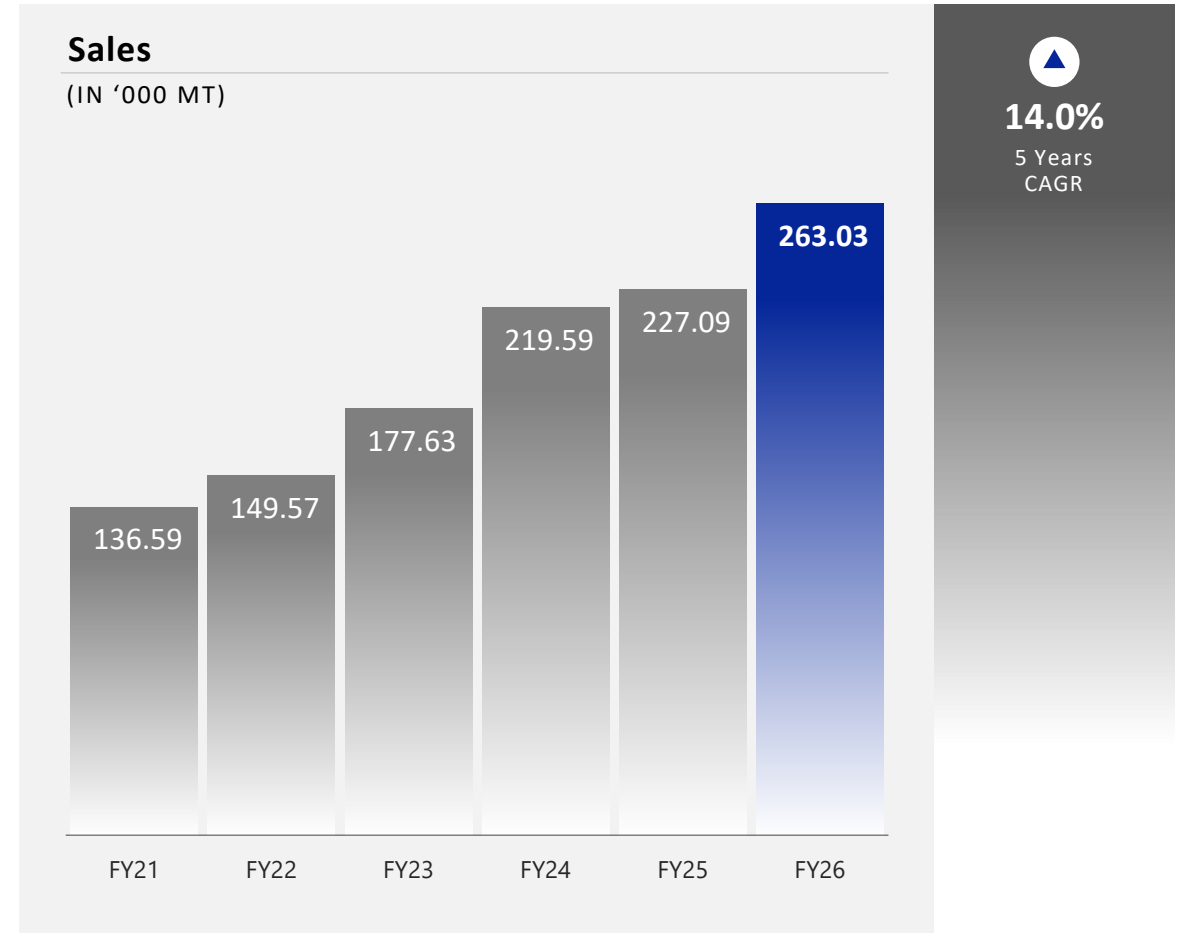
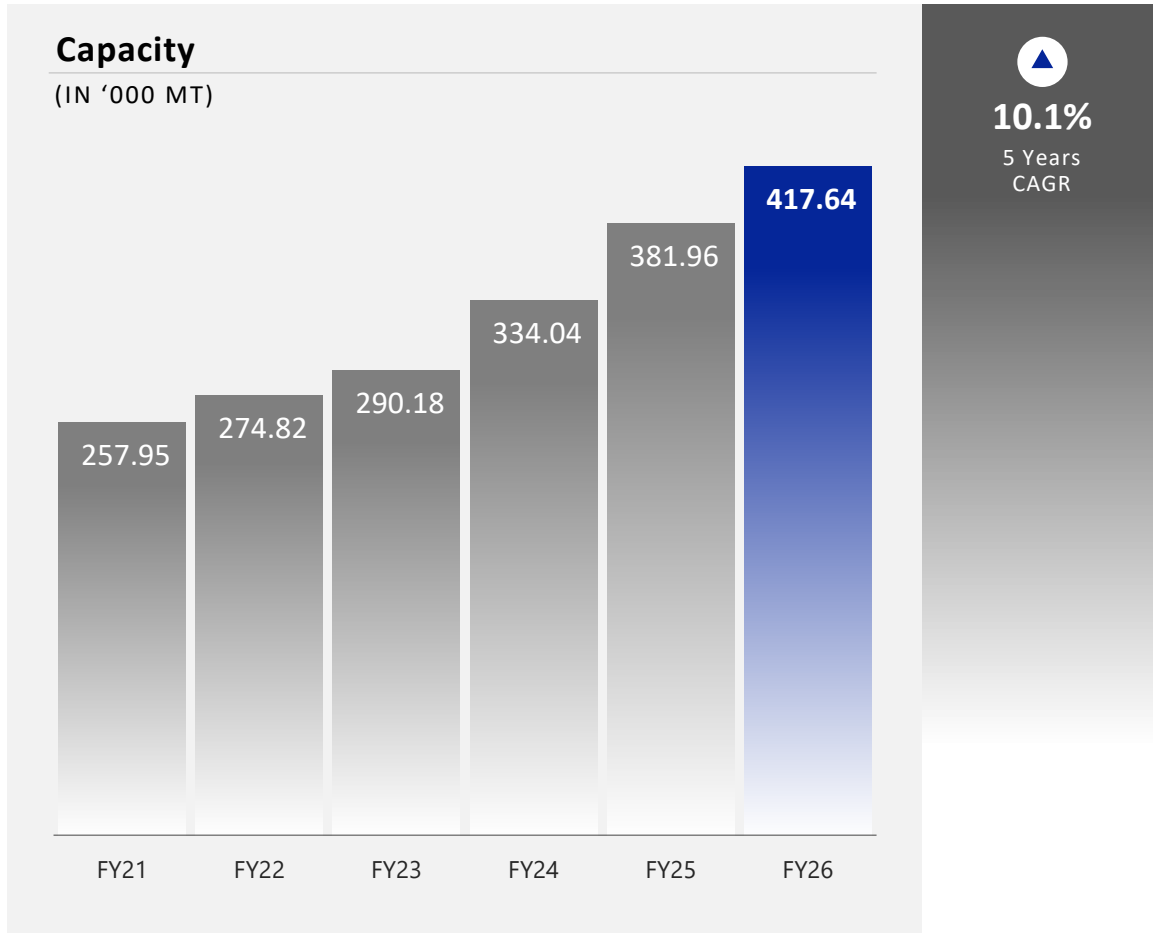

Plumbing Business (3/3)

Working Capital

(IN DAYS)

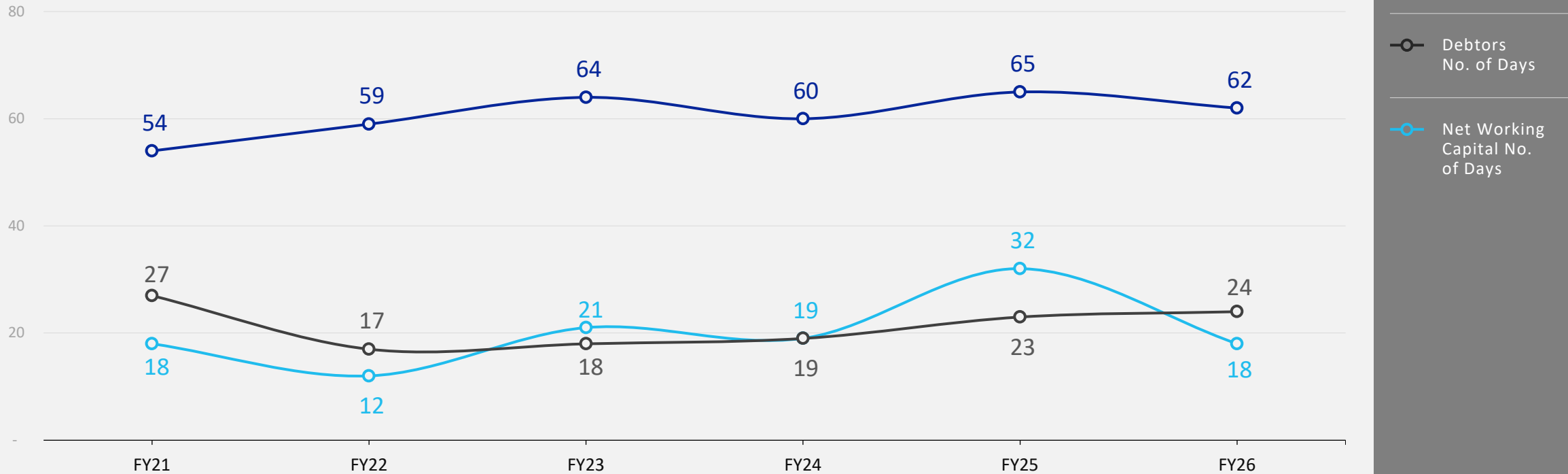

Paints and Adhesives Business

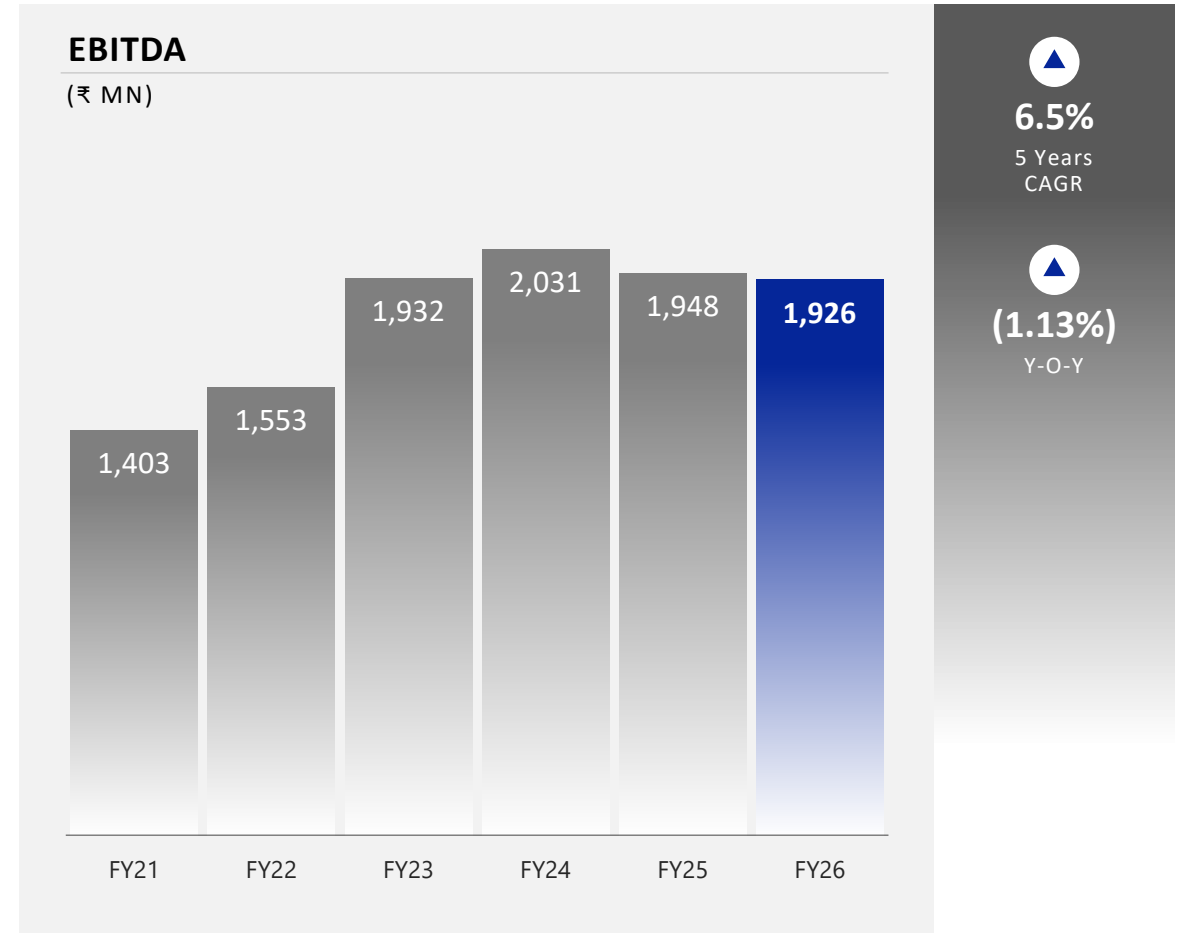
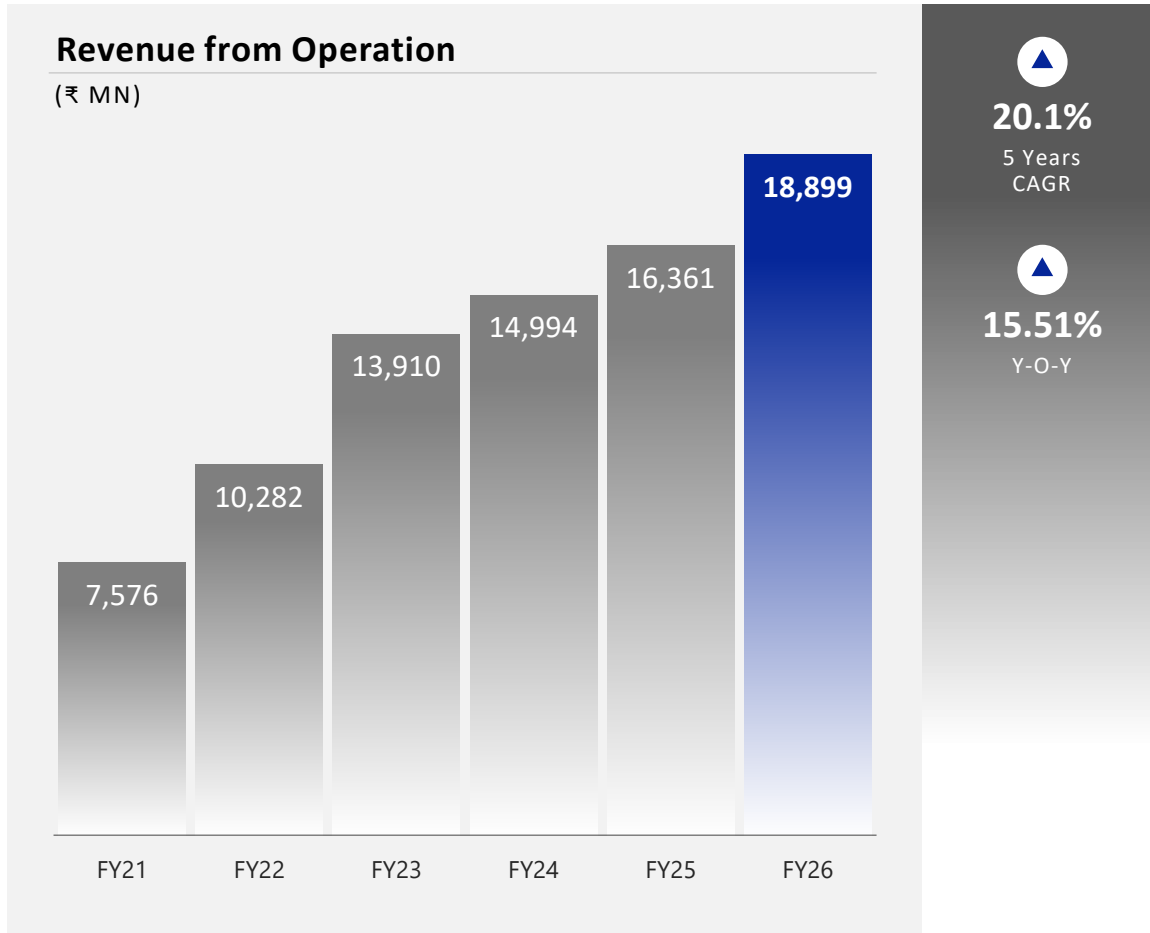

Disclaimer



The information in this presentation has been prepared for use in presentations by Astral Limited (the “Company”) for information purposes only and does not constitute, or should be regarded as, or form part of any offer, invitation, inducement or advertisement to sell or issue, or any solicitation or initiation of any offer to purchase or subscribe for, any securities of the Company in any jurisdiction, nor shall it, or the fact of its distribution form the basis of, or be relied on in connection with, any investment decision or any contract or commitment to purchase or subscribe for any securities of the Company in any jurisdiction.

No representation or warranty, express or implied, is made as to, and no reliance should be placed on, the fairness, accuracy, completeness or correctness of the information or opinions contained in this presentation. Neither the Company nor any of its affiliates, advisors or representatives shall have any responsibility or liability whatsoever (for negligence or otherwise) for any loss howsoever arising from any use of this presentation or its contents or otherwise arising in connection with this presentation. The information set out herein may be subject to updating, completion, revision, verification and amendment and such information may change materially. This presentation is based on the economic, regulatory, market and other conditions as in effect on the date hereof. It should be understood that subsequent developments may affect the information contained in this presentation, which neither the Company nor its affiliates, advisors or representatives are under an obligation to update, revise or affirm.

This presentation contains forward-looking statements based on the currently held beliefs and assumptions of the management of the Company, which are expressed in good faith and, in their opinion, reasonable. Forward-looking statements involve known and unknown risks, uncertainties and other factors, which may cause the actual results, financial condition, performance, or achievements of the Company or industry results, to differ materially from the results, financial condition, performance or achievements expressed or implied by such forward-looking statements. Unless otherwise indicated, the information contained herein is preliminary and indicative and is based on management information, current plans and estimates. Industry and market-related information is obtained or derived from industry publications and other sources and has not been independently verified by us. Given these risks, uncertainties and other factors, recipients of this document are cautioned not to place undue reliance on these forward-looking statements. The Company disclaims any obligation to update these forward-looking statements to reflect future events or developments.

ASTRAL LIMITED



Thank You

Contact Us

**REGISTERED & CORPORATE OFFICE
AHMEDABAD**

ASTRAL LIMITED
"ASTRAL HOUSE" 207/1,
Behind Rajpath Club,
Off. S.G. Highway,
Ahmedabad - 380059, India.

M: +91-79-66212000 | +91-79-66212121
W: info@astralltd.com

